

# Absolute Encoders - Singleturn

<b>Standard Optical</b>	<b>Sendix 5858 / 5878 (Shaft / Hollow shaft)</b>	<b>EtherCAT</b>
-------------------------	--	-----------------



The singleturn encoders 5858 and 5878 with second-generation EtherCAT interface and optical sensor technology are ideal for use in all applications with an EtherCAT interface.

The data communication is based on CAN over EtherNet and ideally suited for use in real time applications.

These encoders are available with a solid shaft up to a maximum of 10 mm or a blind hollow shaft up to 15 mm.

Absolute Encoders Singleturn

Safety-Lock™	High rotational speed	Temperature range -40°... +80°C	High protection level IP67	High shaft load capacity	Shock / vibration resistant	Magnetic field proof	Short-circuit proof	Reverse polarity protection	Optical sensor	Seawater-resistant version on request

## Reliable

- EtherCAT conformance tested
- Integration of the latest Slave – EtherCAT stack from Beckhoff, Version 5.01
- Ideally suited for use in harsh outdoor environments, thanks to IP67 protection and rugged housing construction

## Flexible

- Use of CoE (CAN over EtherNet)
- Genuine new position information as a result of minimal cycle time of 62.5 µs in the DC mode
- Faster, easier error-free connection thanks to M12 connectors

<b>Order code</b>	<b>8.5858</b>	<b>Shaft version</b>	<b>. X X B 2 . B2 12</b>	<p>If for each parameter of an encoder the <b>underlined preferred option</b> is selected, then the delivery time will be 10 working days for a maximum of 10 pieces. Qts. up to 50 pcs. of these types generally have a delivery time of 15 working days.</p>	
	Type	a	b c d e		
		<b>a Flange</b>	<b>b Shaft (ø x L), with flat</b>	<b>c Interface / Power supply</b>	<b>e Fieldbus profile</b>
		<u>1</u> = clamping flange, IP65 ø 58 mm [2.28"] 3 = clamping flange, IP67 ø 58 mm [2.28"] <u>2</u> = synchro flange, IP65 ø 58 mm [2.28"] 4 = synchro flange, IP67 ø 58 mm [2.28"] 5 = square flange, IP65 □ 63.5 mm [2.5"] 7 = square flange, IP67 □ 63.5 mm [2.5"]	<u>1</u> = 6 x 10 mm [0.24 x 0.39"] <sup>1)</sup> <u>2</u> = 10 x 20 mm [0.39 x 0.79"] <sup>2)</sup> 3 = 1/4" x 7/8" 4 = 3/8" x 7/8"	<u>B</u> = EtherCAT / 10 ... 30 V DC	<u>B2</u> = EtherCAT with CoE (CAN over EtherNet)
				<b>d Type of connection</b> removable bus terminal cover <u>2</u> = 3 x M12 connector	optional on request - Ex 2/22 - seawater-resistant

<b>Order code</b>	<b>8.5878</b>	<b>Hollow shaft</b>	<b>. X X B 2 . B2 12</b>	<p>If for each parameter of an encoder the <b>underlined preferred option</b> is selected, then the delivery time will be 10 working days for a maximum of 10 pieces. Qts. up to 50 pcs. of these types generally have a delivery time of 15 working days.</p>	
	Type	a	b c d e		
		<b>a Flange</b>	<b>b Hollow shaft</b>	<b>c Interface / Power supply</b>	<b>e Fieldbus profile</b>
		1 = with spring element long, IP65 2 = with spring element long, IP67 3 = with stator coupling, IP65 ø 65 mm [2.56"] 4 = with stator coupling, IP67 ø 65 mm [2.56"] <u>5</u> = with stator coupling, IP65 ø 63 mm [2.48"] 6 = with stator coupling, IP67 ø 63 mm [2.48"]	<u>3</u> = ø 10 mm [0.39"] <u>4</u> = ø 12 mm [0.47"] 5 = ø 14 mm [0.55"] 6 = ø 15 mm [0.59"] 8 = ø 3/8" 9 = ø 1/2"	<u>B</u> = EtherCAT / 10 ... 30 V DC	<u>B2</u> = EtherCAT with CoE (CAN over EtherNet)
				<b>d Type of connection</b> removable bus terminal cover <u>2</u> = 3 x M12 connector	optional on request - Ex 2/22 - seawater-resistant

1) Preferred type only in conjunction with flange type 2  
2) Preferred type only in conjunction with flange type 1

# Absolute Encoders - Singleturn

<b>Standard Optical</b>	<b>Sendix 5858 / 5878 (Shaft / Hollow shaft)</b>	<b>EtherCAT</b>
-------------------------	--	-----------------

Mounting accessory for shaft encoders		Order No.
<b>Coupling</b>	Bellows coupling $\varnothing$ 19 mm [0.75"] for shaft 6 mm [0.24"]	<b>8.0000.1101.0606</b>
	Bellows coupling $\varnothing$ 19 mm [0.75"] for shaft 10 mm [0.39"]	<b>8.0000.1101.1010</b>

Mounting accessory for hollow shaft encoders		Order No.
<b>Cylindrical pin, long</b> for torque stops	With fixing thread 	<b>8.0010.4700.0000</b>

Connection technology		
<b>Connector, self-assembly (straight)</b>	Coupling M12 for Port IN and Port OUT Connector M12 for power supply	<b>05.WASCSY4S</b> <b>05.B8141-0</b>
<b>Cordset, pre-assembled</b>	M12 for Port IN and Port OUT, 2 m [6.56'] PUR cable M12 for power supply, 2 m [6.56'] PUR cable	<b>05.00.6031.4411.002M</b> <b>05.00.6061.6211.002M</b>

Further accessories can be found in the accessories section or in the accessories area of our website at: [www.kuebler.com/accessories](http://www.kuebler.com/accessories)  
Additional connectors can be found in the connection technology section or in the connection technology area of our website at: [www.kuebler.com/connection\\_technology](http://www.kuebler.com/connection_technology)

## Technical data

Mechanical characteristics		
<b>Max. speed</b>	IP65 up to 70°C [158°F] IP65 up to T <sub>max</sub> IP67 up to 70°C [158°F] IP67 up to T <sub>max</sub>	9 000 min <sup>-1</sup> , 7 000 min <sup>-1</sup> (continuous) 7 000 min <sup>-1</sup> , 4 000 min <sup>-1</sup> (continuous) 8 000 min <sup>-1</sup> , 6 000 min <sup>-1</sup> (continuous) 6 000 min <sup>-1</sup> , 3 000 min <sup>-1</sup> (continuous)
<b>Starting torque - at 20°C [68°F]</b>	IP65 IP67	< 0.01 Nm < 0.05 Nm
<b>Moment of inertia</b>	shaft version hollow shaft version	3.0 x 10 <sup>-6</sup> kgm <sup>2</sup> 6.0 x 10 <sup>-6</sup> kgm <sup>2</sup>
<b>Load capacity of shaft</b>	radial axial	80 N 40 N
<b>Weight</b>		approx. 0.50 kg [17.64 oz]
<b>Protection acc. to EN 60529</b>	housing side shaft side	IP67 IP65, opt. IP67
<b>EX approval for hazardous areas</b>		optional Zone 2 and 22
<b>Working temperature range</b>		-40°C ... +80°C [-40°F ... +176°F]
<b>Material</b>	shaft/hollow shaft flange housing	stainless steel aluminium zinc die-cast housing
<b>Shock resistance acc. EN 60068-2-27</b>		2500 m/s <sup>2</sup> , 6 ms
<b>Vibration resistance acc. EN 60068-2-6</b>		100 m/s <sup>2</sup> , 55 ... 2000 Hz

Electrical characteristics	
<b>Power supply</b>	10 ... 30 V DC
<b>Power consumption (no load)</b>	max. 110 mA
<b>Reverse polarity protection of the power supply (+V)</b>	yes
<b>UL approval</b>	File 224618
<b>CE compliant acc. to</b>	EMC guideline 2004/108/EC
<b>RoHS compliant acc. to</b>	guideline 2011/65/EU

Device characteristics	
<b>Singleturn resolution</b>	1 ... 65535 (16 bit), scaleable
<b>Default value</b>	8192 (13 bit)
<b>Total resolution</b>	scaleable from 1 up to 65535 (16 bit)
<b>Code</b>	binary
<b>Protocol</b>	EtherNet / EtherCAT

Diagnostic LED (red)
LED is ON with the following fault conditions: Sensor error (internal code or LED error), low voltage, over-temperature

Run LED (green)
LED is ON with the following conditions: Preop-, Safeop and Op-State (EtherCAT Status machine)

2 x Link LEDs (yellow)
LED is ON with the following conditions (Port IN and Port OUT): Link detected

Modes
Freerun, Distributed Clock

# Absolute Encoders - Singleturn

<b>Standard Optical</b>	<b>Sendix 5858 / 5878 (Shaft / Hollow shaft)</b>	<b>EtherCAT</b>
-------------------------	--	-----------------

### General information about CoE (CAN over EtherNet)

The EtherCAT encoders support the CANopen communication profile according to DS301. In addition device-specific profiles like the encoder profile DS406 are available.

Scaling, preset values, limit switch values and many other parameters can be programmed via the EtherCAT bus.

When switching the device on, all parameters are loaded from an EEPROM, where they were saved previously to protect them against power-failure.

The following output values may be combined as PDO (PDO mapping): **position**, **speed**, **temperature values** and **working area state** as well as other process values.

### CANopen encoder profile 3.2.10 CoE (CAN over EtherNet)

The following parameters are programmable:

- Position update time of 62.5  $\mu$ s
- EtherCAT certificate of conformity
- Speed with sign
- Four units for speed calculation: Steps/sec, Steps/100 ms, Steps/10 ms, RPM
- Time stamp as system time at the point in time when the position is read out
- Two working area state registers
- Along with the scaled position, the raw data – position as process value – is also mappable
- Dynamic Mapping
- Gating Time: setting of the time interval, via which the speed value can be interpolated
- Sensor temperature in degrees Celsius
- Comprehensive plausibility test when downloading parameters to the encoder
- Alarm and warning messages
- User interface with visual display of bus and fault status – 4 LEDs
- Extended error management for position sensing with integrated temperature control
- Implementation of the latest CANopen profile 3.2.10 from the 18th February 2011

Absolute Encoders  
Singleturn

### Terminal assignment bus

Interface	Type of connection	Function	M12 connector					Diagram
			Signal:	Transmit data+	Receive data+	Transmit data -	Receive data -	
B	2 (3 x M12 connector)	Bus Port IN	Signal:	Transmit data+	Receive data+	Transmit data -	Receive data -	
			Abbreviation:	TxD+	RxD+	TxD-	RxD-	
			Pin:	1	2	3	4	
		Power supply	Signal:	Voltage +	–	Voltage –	–	
			Abbreviation:	+ V	–	0 V	–	
			Pin:	1	2	3	4	
		Bus Port OUT	Signal:	Transmit data+	Receive data+	Transmit data -	Receive data -	
			Abbreviation:	TxD+	RxD+	TxD-	RxD-	
			Pin:	1	2	3	4	

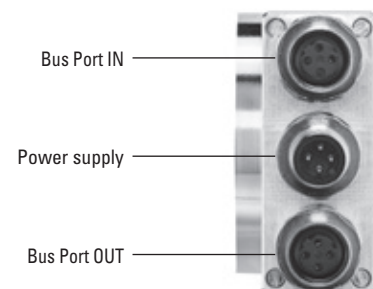

# Absolute Encoders - Singleturn

**Standard  
Optical**

**Sendix 5858 / 5878 (Shaft / Hollow shaft)**

**EtherCAT**

## Dimensions shaft version, with removable bus terminal cover

Dimensions in mm [inch]

### Clamping flange, $\varnothing$ 58 [2.28] Flange type 1 and 3

- 1 3 x M3, 6 [0.24] deep
- 2 3 x M4, 8 [0.32] deep

D	L	Fit
6 [0.24]	10 [0.39]	h7
10 [0.39]	20 [0.79]	f7
1/4"	7/8"	h7
3/8"	7/8"	h7

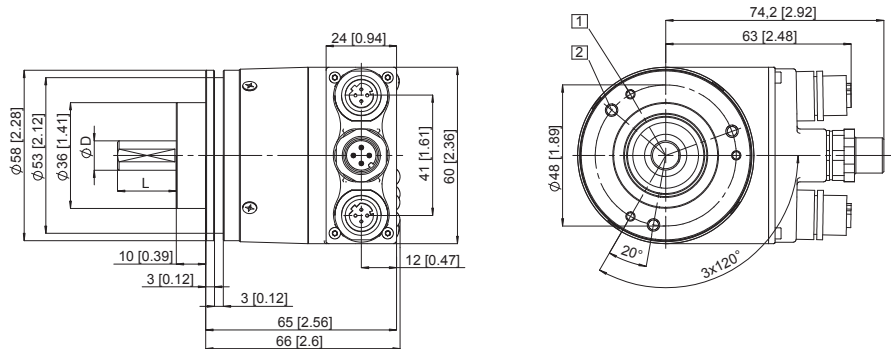

### Synchro flange, $\varnothing$ 58 [2.28] Flange type 2 and 4

- 1 3 x M4, 6 [0.24] deep

D	L	Fit
6 [0.24]	10 [0.39]	h7
10 [0.39]	20 [0.79]	f7
1/4"	7/8"	h7
3/8"	7/8"	h7

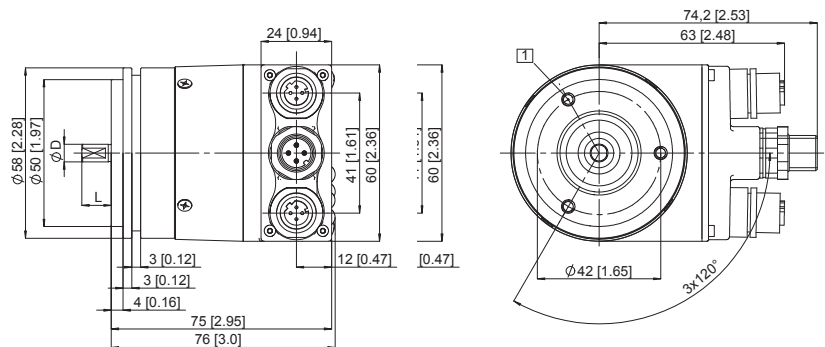

### Square flange, $\square$ 63.5 [2.5] Flange type 5 and 7

D	L	Fit
6 [0.24]	10 [0.39]	h7
10 [0.39]	20 [0.79]	f7
1/4"	7/8"	h7
3/8"	7/8"	h7

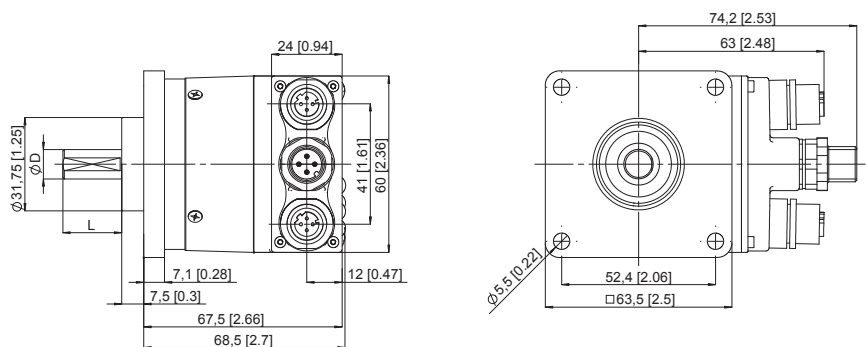

# Absolute Encoders - Singleturn

<b>Standard Optical</b>	<b>Sendix 5858 / 5878 (Shaft / Hollow shaft)</b>	<b>EtherCAT</b>
-------------------------	--	-----------------

## Dimensions hollow shaft version (blind hollow shaft), with removable bus terminal cover

Dimensions in mm [inch]

### Flange with spring element long Flange type 1 and 2

- 1 Torque stop slot,  
Recommendation:  
Cylindrical pin DIN 7,  $\varnothing 4$  [0.16]
  - 2 3 x M3, 5.5 [0.21] deep
  - 3 Recommended torque for the  
clamping ring 0.6 Nm
- L: Insertion depth for blind hollow shaft:  
30 [1.18]

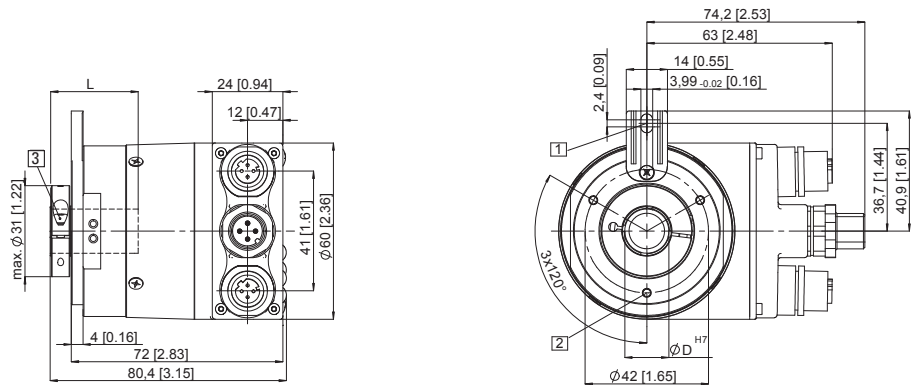

### Flange with stator coupling, $\varnothing 63$ [2.48] Flange type 5 and 6

- 1 Fixing screws DIN 912 M3 x 8  
(Washer included in delivery)
  - 2 Recommended torque for the  
clamping ring 0.6 Nm
- L: Insertion depth for blind hollow shaft:  
30 [1.18]

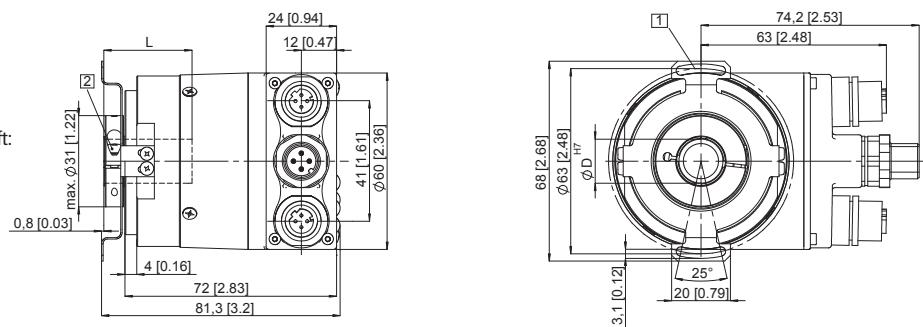

### Flange with stator coupling, $\varnothing 65$ [2.56] Flange type 3 and 4

- 1 Recommended torque for the  
clamping ring 0.6 Nm
- L: Insertion depth for blind hollow shaft:  
30 [1.18]

