

Absolute Encoders - Singleturn

Standard ATEX, optical	Sendix 7058 (Shaft)	CANopen
----------------------------------	----------------------------	----------------



The Sendix 7058 absolute singleturn encoders offer Ex protection in a compact 70 mm seawater resistant housing, with a CANopen interface and optical sensor technology.

These shock and vibration-resistant encoders operate flexibly with a resolution of up to 16 bits; they are also available with axial and radial cable outlets



Absolute Encoders Singleturn

Ex approval	Safety-Lock™	High rotational speed	High protection level	High shaft load capacity	Shock / vibration resistant	Magnetic field proof	Short-circuit proof	Reverse polarity protection	Optical sensor	Seawater-resistant

Compact and Safe

- Can be used even when space is tight
- Minimal installation depth, diameter 70 mm
- Compact cable outlet axial or radial
- Can be operated in marine environments – housing and flange manufactured from seawater-resistant aluminium
- Remains sealed even in harsh everyday use and ensures highest safety against field breakdowns (IP67 protection)

Explosion protection

- “Flameproof-enclosure” version
- ATEX with EC type examination certificate
- IECEx with Certificate of Conformity (CoC)

Order code	8.7058	.1	X	2	X	.21	11	.XXXX	
Shaft version	Type	a	b	c	d	e	f ¹⁾		
a Flange	1 = clamping-synchronous flange, IP67, ø 70 mm [2.76"]	d Type of connection					f Cable length in dm ¹⁾		
b Shaft (ø x L)	2 = 10 x 20 mm [0.39 x 0.79"], with flat 1 = 12 x 25 mm [0.47 x 0.98"], with keyway for 4 x 4 mm [0.16 x 0.16"] key	1 = axial cable, 2 m [6.56'] PUR 2 = radial cable, 2 m [6.56'] PUR A = axial cable, length > 2 m [6.56'] B = radial cable, length > 2 m [6.56'] preferred length see f , e. g.: 0100 = 10 m [32.81']					0050 = 5 m [16.40'] 0100 = 10 m [32.81'] 0150 = 15 m [49.21']		
c Interface / Power supply	2 = CANopen DS301 V4.02 / 10 ... 30 V DC	e Fieldbus profile					21 = CANopen encoder profile DS406 V3.2		
						optional on request - special cable length			

Mounting accessory for shaft encoders		Order No.
Coupling	Bellows coupling ø 19 mm [0.75"] for shaft 10 mm [0.39"]	8.0000.1101.1010
Programming set	Including: - Interface converter USB-CAN - Connection cable from interface converter to encoder - Power supply 90 ... 250 V AC - DVD with Ezturn® software Minimum system requirements: Operating system: WinXP SP3 or higher Processor: 1 GHz RAM: 512 MB Required disk space: 500 MB	8.0010.9000.0015

Further accessories can be found in the accessories section or in the accessories area of our website at: www.kuebler.com/accessories
 Additional connectors can be found in the connection technology section or in the connection technology area of our website at: www.kuebler.com/connection_technology

1) Not applicable with connection types 1 and 2

Absolute Encoders - Singleturn

Standard ATEX, optical	Sendix 7058 (Shaft)	CANopen
-----------------------------------	----------------------------	----------------

Technical data

Explosion protection ATEX	
EC type-examination certificate	PTB09 ATEX 1106 X
Category (gas)	II 2 G Ex d IIC T4 - T6 Gb
Category (dust)	II 2D Ex tb IIIC T135°C - T85°C Db IP6x
Directive 94/9/EC	EN 60079-0: 2009; EN 60079-1: 2007; EN 60079-31: 2009

Explosion protection IECEx	
Certificate of Conformity (CoC)	IECEx PTB 13.0026 X
Category (gas)	Ex d IIC T4 - T6 Gb
Category (dust)	Ex tb IIIC T135°C - T85°C Db IP6x
IECEx	IEC 60079-0:2007; IEC 60079-1:2007; IEC 60079-31:2008

Mechanical characteristics	
Max. speed	continuous 6 000 min ⁻¹
Starting torque – at 20°C [68°F]	< 0.05 Nm
Moment of inertia	4.0 x 10 ⁻⁶ kgm ²
Load capacity of shaft	radial 80 N axial 40 N
Weight	approx. 1.3 kg [45.86 oz]
Protection acc. to EN 60529	IP67
Working temperature range	-40°C ... +60°C [-40 ... +140°F]
Material	shaft stainless steel flange / housing seawater-resistant Al, type AlSiMgMn (EN AW-6082) (stainless steel on req.) cable PUR
Shock resistance acc. to EN 60068-2-27	2500 m/s ² , 6 ms
Vibration resistance acc. to EN 60068-2-6	100 m/s ² , 55 ... 2000 Hz

Electrical characteristics	
Power supply	10 ... 30 V DC
Current consumption (no load)	max. 110 mA
Reverse polarity protection for power supply (+V)	yes
CE compliant acc. to	EMC guideline 2004/108/EC ATEX guideline 94/9/EC
RoHS compliant acc. to	guideline 2002/95/EC

Interface characteristics CANopen	
Resolution	1 ... 65536 (16 bit) (scalable: 1 ... 65536)
Default value	8192 (13 bit)
Code	Binary
Interface	CAN High-Speed acc. to ISO 11898, Basic- and Full-CAN, CAN Specification 2.0 B
Protocol	CANopen Profile DS406 V3.2 with manufacturer-specific add-ons
Baud rate	10 ... 1000 kbit/s (Software configurable)
Node address	1 ... 127 (Software configurable)
Switchable termination	Software configurable

General information about CANopen

The CANopen encoders support the latest CANopen communication profile according to DS301 V4.02 .

In addition, device-specific profiles like the encoder profile DS406 V3.2 are available.

The following operating modes may be selected: Polled Mode, Cyclic Mode, Sync Mode and a High Resolution Sync Protocol. Moreover, scale factors, preset values, limit switch values and many other additional parameters can be programmed via the CANbus. When switching the device on, all parameters are loaded from an EEPROM, where they were saved previously to protect them against power-failure.

As output values **position, speed, acceleration** as well as the **working area status** may be combined freely as PDO (PDO mapping)

CANopen Communication Profile DS301 V4.02

Among others, the following functionality is integrated:

Class C2 functionality

- NMT Slave
- Heartbeat Protocol
- High Resolution Sync Protocol
- Identity Object
- Error Behaviour Object
- Variable PDO Mapping self-start programmable (Power on to operational), 3 Sending PDO's
- Node address, baud rate and CANbus Programmable termination

CANopen Encoder Profile DS406 V3.2

The following parameters can be programmed:

- Event mode
- Units for speed selectable (Steps/Sec or RPM)
- Factor for speed calculation (e.g. measuring wheel circumference)
Integration time for speed value of 1...32
- 2 work areas with 2 upper and lower limits and the corresponding output states
- Variable PDO mapping of position, speed, acceleration, working area status
- Extended failure management for position sensing with integrated temperature control
- User interface with visual display of bus and failure status - 3 LED's
- Optional - 32 CAMs programmable
- Customer-specific memory - 16 Bytes

Absolute Encoders - Singleturn

Standard ATEX, optical	Sendix 7058 (Shaft)	CANopen
-----------------------------------	----------------------------	----------------

Terminal assignment

Interface	Type of connection	Cable (isolate unused wires individually before initial start-up)								
		Signal:	0 V	+V	CAN_H	CAN_L	CAN_GND	CAN_H	CAN_L	CAN_GND
2	1, 2, A, B	Cable marking:	1	2	4	5	6	7	8	9

Dimensions

Dimensions in mm [inch]

Clamping-synchronous flange, $\varnothing 70$ [2.76] Shaft type 1 with axial cable outlet

- 1 6 x M4, 10 [0.39] deep
- 2 Keyway for DIN 6885-A-4x4x25 key

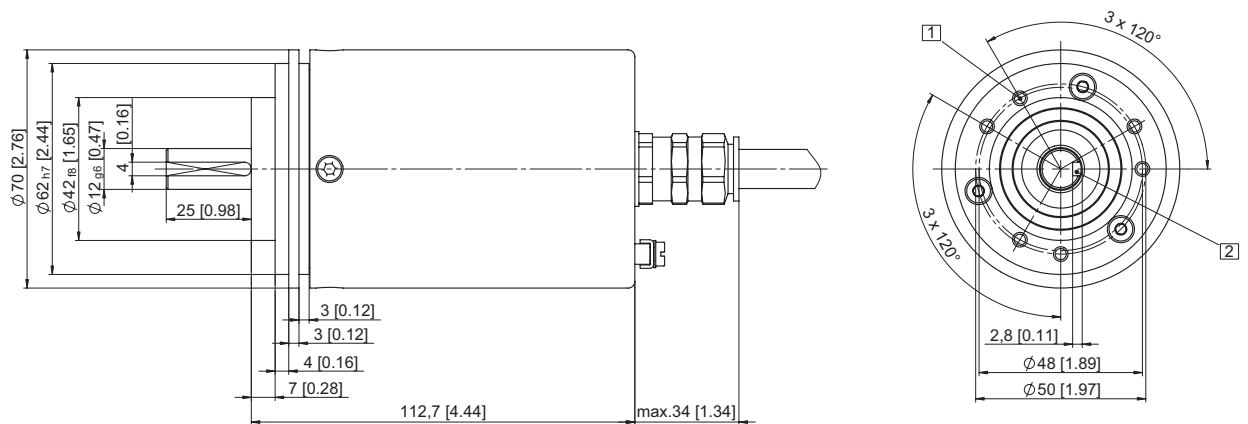

Clamping-synchronous flange, $\varnothing 70$ [2.76] Shaft type 2 with radial cable outlet

- 1 6 x M4, 10 [0.39] deep

