

# Absolute Encoders - Singleturn

<b>Standard</b> ATEX, SIL3/PLe, optical	<b>Sendix 7053FS3 (Shaft)</b>	<b>SSI/BiSS-C + SinCos</b>
--	-------------------------------	----------------------------



Ex protection and Functional Safety in one device.

The absolute singleturn encoders 7053 FS3 of the Sendix SIL family are suited for use in safety-related applications up to SIL3 acc. to EN 61800-5-2 or PLe to EN ISO 13849-1.

In addition, these devices ensure Ex protection in a compact 70 mm housing out of seawater-resistant aluminium.



## Functional Safety

- Encoder with individual certificate from IFA / TÜV
- Suitable for applications up to SIL3 acc. to EN 61800-5-2
- Suitable for applications up to PLe acc. to EN ISO 13849-1
- SSI or BiSS-C interface with incremental SinCos tracks with 2048 ppr
- Certified mechanical mounting + electronic

## Explosion protection

- "Flameproof-enclosure" version
- ATEX with EC type examination certificate
- IECEx with Certificate of Conformity (CoC)

**Order code** 8.7053 FS3 . 1 X 4 X . X X 2 1 . XXXX  
**Shaft version** Type

- |   |  |   |
|---|--|---|
| <p><b>a</b> Flange<br/>1 = clamping-synchronous flange, IP67, ø 70 mm [2.76"]</p> <p><b>b</b> Shaft (ø x L)<br/>2 = 10 x 20 mm [0.39 x 0.79"], with flat<br/>1 = 12 x 25 mm [0.47 x 0.98"], with keyway for 4 x 4 mm [0.16 x 0.16"] key</p> <p><b>c</b> Interface / Power supply<br/>4 = SSI or BiSS-C + 2048 ppr SinCos / 10 ... 30 V DC</p> <p><b>d</b> Type of connection<br/>1 = axial cable, 2 m [6.56'] PUR<br/>2 = radial cable, 2 m [6.56'] PUR<br/>A = axial cable, length &gt; 2 m [6.56']<br/>B = radial cable, length &gt; 2 m [6.56']<br/>preferred length see <b>i</b>, e. g.: 0100 = 10 m [32.81']</p> | <p><b>e</b> Code<br/>B = SSI, Binary<br/>C = BiSS-C, Binary<br/>G = SSI, Gray</p> <p><b>f</b> Resolution <sup>2)</sup><br/>A = 10 bit ST<br/>1 = 11 bit ST<br/>2 = 12 bit ST<br/>3 = 13 bit ST<br/>4 = 14 bit ST<br/>7 = 17 bit ST</p> | <p><b>g</b> Inputs / Outputs <sup>2)</sup><br/>2 = SET input</p> <p><b>h</b> Options<br/>1 = no option</p> <p><b>i</b> Cable length in dm <sup>1)</sup><br/>0050 = 5 m [16.40']<br/>0100 = 10 m [32.81']<br/>0150 = 15 m [49.21']</p> <p style="text-align: right;"><i>optional on request<br/>- special cable length</i></p> |
|---|--|---|

Accessories safety control		Order No.
<b>Safety-M, basic modules</b>	Speed and position monitoring for 1 axis	<b>8.MSP1.000</b>
	Speed and position monitoring for 2 axes (analogue input optional)	<b>8.MSP2.XXX</b>

Further accessories can be found in the accessories section or in the accessories area of our website at: [www.kuebler.com/accessories](http://www.kuebler.com/accessories)  
 Additional connectors can be found in the connection technology section or in the connection technology area of our website at: [www.kuebler.com/connection\\_technology](http://www.kuebler.com/connection_technology)  
 You will find an overview of our systems and components for Functional Safety in the safety technology section or under [www.kuebler.com/safety](http://www.kuebler.com/safety)

1) Not applicable with connection types 1 and 2  
 2) Resolution, preset value and counting direction factory-programmable

# Absolute Encoders - Singleturn

<b>Standard</b> ATEX, SIL3/PLe, optical	<b>Sendix 7053FS3 (Shaft)</b>	<b>SSI/BiSS-C + SinCos</b>
--	-------------------------------	----------------------------

## Technical data

Explosion protection ATEX	
EC type-examination certificate	PTB09 ATEX 1106 X
Category (gas)	II 2 G Ex d IIC T4 - T6 Gb
Category (dust)	II 2D Ex tb IIIC T135°C - T85°C Db IP6x
Directive 94/9/EC	EN 60079-0: 2009; EN 60079-1: 2007; EN 60079-31: 2009

Explosion protection IECEx	
Certificate of Conformity (CoC)	IECEx PTB 13.0026 X
Category (gas)	Ex d IIC T4 - T6 Gb
Category (dust)	Ex tb IIIC T135°C - T85°C Db IP6x
IECEx	IEC 60079-0:2007; IEC 60079-1:2007; IEC 60079-31:2008

Notes regarding "Functional Safety"	
These encoders are suitable for use in safety-related systems up to SIL3 acc. to EN 61800-5-2 and PLe to EN ISO 13849-1 in conjunction with controllers or evaluation units, which possess the necessary functionality. Additional functions can be found in the operating manual.	

Safety characteristics	
Relevant standards	EN ISO 13849-1 / EN 61800-5-2, EN 61508
Classification	PLe / SIL3
System structure	2 channel (Cat. 4 / HFT = 1)
PFH <sub>d</sub> value <sup>1)</sup>	1.09 x 10 <sup>-8</sup> h <sup>-1</sup>
Proof-test interval	20 years

Mechanical characteristics	
Max. speed	continuous 6 000 min <sup>-1</sup>
Starting torque – at 20°C [68°F]	< 0.05 Nm
Moment of inertia	4.0 x 10 <sup>-6</sup> kgm <sup>2</sup>
Load capacity of shaft	radial 80 N axial 40 N
Weight	approx. 1.3 kg [45.86 oz]
Protection acc. to EN 60529	IP67
Working temperature range	-40°C ... +60°C [-40 ... +140°F]
Material	shaft stainless steel flange / housing seawater-resistant Al, type AlSiMgMn (EN AW-6082) stainless steel on req. cable PUR
Shock resistance acc. to EN 60068-2-27	500 m/s <sup>2</sup> , 11 ms
Vibration resistance acc. to EN 60068-2-6	200 m/s <sup>2</sup> , 10 ... 150 Hz

Electrical characteristics	
Power supply	10 ... 30 V DC
Current consumption (no load)	max. 45 mA
Reverse polarity protection for power supply (+V)	yes
Short circuit proof outputs	yes <sup>2)</sup>
CE compliant acc. to	EMC guideline 2004/108/EC ATEX guideline 94/9/EC Machinery directive 2006/42/EC
RoHS compliant acc. to	guideline 2002/95/EC

SSI interface	
Output driver	RS485 transceiver type
Permissible load / channel	max. 20 mA
Signal level	HIGH typ 3.8 V LOW at I <sub>Load</sub> = 20 mA typ 1.3 V
Singleturn resolution	10...14 bit and 17 bit <sup>3)</sup>
Number of revolutions	4096 (12 bit)
Code	Binary or Gray
SSI clock rate	resolution ≤ 14 bit 50 kHz ... 2 MHz resolution ≥ 15 bit 50 kHz ... 125 kHz
Monoflop time	≤ 15 μs
Note: if clock starts cycling within monoflop time a second data transfer starts with the same data. If clock starts cycling after monoflop time, the data transfer starts with updated values. The update rate depends on clock speed, data length and monoflop time.	
Data refresh rate	resolution ≤ 14 bit ≤ 1 μs resolution ≥ 15 bit 4 μs
Status and parity bit	on request

BiSS-C interface	
Singleturn resolution	10 ... 14 bit and 17 bit <sup>3)</sup>
Code	Binary
Clock rate	up to 10 MHz
Max. update rate	< 10 μs, depends on the clock rate and the data length
Data refresh rate	≤ 1 μs
Note:	– Bidirectional, factory programmable parameters are: resolution, code, direction, alarms and warnings – CRC data verification

SinCos interface	
Max. frequency -3dB	400 kHz
Signal level	1 V <sub>pp</sub> (± 10%)
Short circuit proof	yes
Pulse rate	2048 ppr

SET input	
Input	high active
Input type	Comparator
Signal level (+V = Power supply)	HIGH min. 60 % of +V max. +V LOW max. 25 % of +V
Input current	< 0.5 mA
Min. pulse duration (SET)	10 ms
Timeout after SET signal	14 ms

The encoder can be set to zero at any position by means of a High signal on the SET input. Other preset values can be factory-programmed. The SET input has a signal delay time of approximately 1 ms. Once the SET function has been triggered, the encoder requires an internal processing time of approximately 15 ms before the new position data can be read.

- 1) The specified value is based on a diagnostic coverage of 99%, that must be achieved with an encoder evaluation unit. The encoder evaluation unit must meet at least the requirements for SIL3.
- 2) Short circuit to 0 V or to output, one channel at a time, power supply correctly applied
- 3) Other options on request

# Absolute Encoders - Singleturn

<b>Standard</b> ATEX, SIL3/PLe, optical	<b>Sendix 7053FS3 (Shaft)</b>	<b>SSI/BiSS-C + SinCos</b>
--	-------------------------------	----------------------------

**Power-ON delay**  
After Power-ON, the device requires a time of approximately 150 ms before valid data can be read.

## Terminal assignment

Interface	Type of connection	Features	Cable (isolate unused wires individually before initial start-up)												
			Signal:	0 V	+V	C+	C-	D+	D-	SET	A	$\bar{A}$	B	$\bar{B}$	$\perp$
4	1, 2, A, B	SET	Cable marking:	6	1	2	3	4	5	11	7	8	9	10	shield

- +V: Encoder power supply +V DC
- 0 V: Encoder power supply ground GND (0 V)
- C+, C-: Clock signal
- D+, D-: Data signal
- SET: SET input. The current position becomes defined as position zero.
- A,  $\bar{A}$ : Cosine signal
- B,  $\bar{B}$ : Sine signal
- $\perp$ : Protective earth

## Dimensions

Dimensions in mm [inch]

### Clamping-synchronous flange, $\varnothing 70$ [2.76] Shaft type 1 with axial cable outlet

- 1 6 x M4, 10 [0.39] deep
- 2 Keyway for DIN 6885-A-4x4x25 key

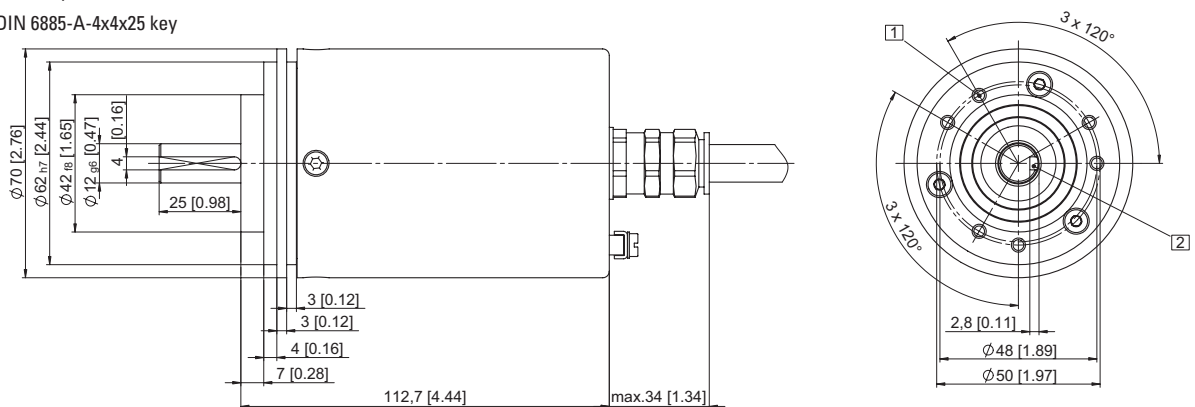

### Clamping-synchronous flange, $\varnothing 70$ [2.76] Shaft type 2 with radial cable outlet

- 1 6 x M4, 10 [0.39] deep

